

General exercises on the Second term

Answer the following questions :

1) Choose the correct answer for each statement of the following :

1- On heating copper hydroxide, we obtain

- a- copper carbonate and water
- b- copper oxide and water vapour
- c- copper and hydrogen
- d- copper oxide and hydrogen

2- Substitution reactions take place on replacing

- a- less active element with more active one.
- b- less active compound with more active one.
- c- more active element with less active one.
- d- more active compound with less active one.

3- The intensity of electric current passing through a circuit can be measured by using apparatus .

- a- pyrometer
- b- barometer
- c- voltmeter
- d- ammeter

4- For measuring the potential difference between two terminals of a conductor, we use apparatus .

- a- pyrometer
- b- barometer
- c- voltmeter
- d- ammeter

5- The value of the resistance of an electric conductor in an electric circuit is changed on changing

- a- dimensions of the conductor.
- b- electric current intensity passing through it.
- c- potential difference between its terminals.
- d- other electric circuit components.

Exercise (1)

General exercises on the Second term**2) Give reasons for each of the following:**

- 1- Iron fillings with a certain mass reacts faster with acids than a piece iron has the same mass.
- 2- The steel scourer used for cleaning aluminium burns in a cylinder full of oxygen faster than burning in air.
- 3 - Mendel covered the stigmas of pea plants on studying the colour seed trait.
- 4- A red precipitate is formed on adding magnesium to copper sulphate solution.

3) Compare between each pair of the following:

- 1- Oxidation and oxidizing agents (in terms of their meaning)
- 2- The two testes and ovaries (in concern of their hormones and functions)
- 3- The dominant and recessive traits (in according to their genes)

4) Complete the following statements:

- 1- On passing hydrogen gas over hot copper oxide, copper oxide is converted into
- 2- On adding silver nitrate solution to sodium chloride solution, a white precipitate of is formed
- 3- Chemically ,the chromosome consists of the nucleic acid bonded with protein.

5) Chemical reactions are classified into different types, write the type of each reaction of the following between brackets.

- 1- $\text{H}_2 + \text{CuO} \rightarrow \text{Cu} + \text{H}_2\text{O}$ (.....)
- 2- $\text{KOH} + \text{HCl} \rightarrow \text{KCl} + \text{H}_2\text{O}$ (.....)
- 3- $2 \text{Na} + 2 \text{HCl} \rightarrow 2 \text{NaCl} + \text{H}_2 \uparrow$ (.....)

6) Define each of the following :

- 1- Electric current intensity
- 2- Ammeter
- 3- Electric potential
- 4- Volt

General exercises on the Second term

- | | |
|------------------------|------------------|
| 5- Electric resistance | 6- Ohm |
| 7- Acquired traits | 8- Radioactivity |
| 9- Mutation | 10- Hormone |

7) Mention each of the following :

- 1- Two precautions needed on dealing with radioactive wastes.
- 2- Three ways of protection from radioactive pollution.
- 3- Mendel's first law (law of segregation)
- 4- The disease results due to insulin hormone deficiency
- 5- Radioactive phenomenon.
- 6- Ohm's law.

8) If the potential difference between the two terminals of a conductor is 6volts, and the electric current of intensity 0.5 ampere is passed through it. Calculate the intensity of the electric current passing through this conductor if it is connected with a voltage source of 12 volts.

9) Calculate the quantity of electricity that pass through a conductor of resistance 1000 ohms for 30 minutes, given the potential difference between its two terminals is 220 Volts.

10) You have four electric cells each of emf 1.2 Volt . Show by drawing the method of connecting them to obtain each of the following:

- 1- A battery of emf 1.2 Volt.
- 2- A battery of emf 4.8 Volt.
- 3- A battery of emf 2.4 Volt.

Exercise (1)

General exercises on the Second term

11) Choose from (B) and (C) what suits with (A).

A	B	C
1 - Electric current intensity	- Ohm - Coulomb	- Voltmeter - Ammeter
2 - Potential difference	- Volt - Ampere	- Wattmeter - Ohmmeter
3 - Resistance	- Joule	

12) " Nuclear energy is used in peace purposes"

Mention their most important uses in each of the following fields.

- | | |
|-------------|---------------------------|
| 1- Medicine | 2- Agriculture |
| 3- Industry | 4- Generating electricity |

13) What are the reasons of the spontaneous mutation ?

14) Draw a diagram representing each of the following:

- 1- An electric circuit used to verify Ohm's law
- 2- Alternating current.

15) Compare between the industrial uses of bases and salts.

16) Write a balanced chemical equation that represents each of the following:

- 1- Replacing the hydrogen of an acid by a metal
- 2- Replacing a metal by another metal in one of its salt solutions
- 3- Double substitution reaction
- 4- Neutralization process.

General exercises on the Second term

17) Complete the following chemical equations:

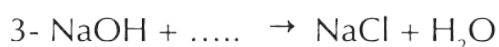
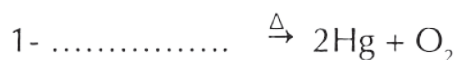

18) Write scientific explanation for each of the following :

1- Ionic compounds reactions are faster than that of covalent ones.

2- The rate of chemical reaction is increased by increasing the temperature.

3- Dwarfism phenomena in humans

19) Compare between direct electric current and alternating electric current in terms of:

1- Their definition

2- Their uses

20) Mention one application for each of the following:

1- Scientific uses of nuclear energy in medicine and agriculture.

2- The use of chemical bases in industry.

21) Complete the following table:

Substance (acid - base - salt)	Economic importance of common acids, bases and salts
.....	Digestion of proteins
.....	Manufacture of glass and cement
Magnesium hydroxide
.....	Manufacture of explosives and fertilizers
Silver nitrate

Exercise (2)

General exercises on the Second term

- Answer the following questions:

1) Complete the following sentences:

1- Ammonium nitrate is decomposed by heat into
and

2- $\text{CuCO}_3 \xrightarrow{\Delta} \dots + \dots$

3- $\text{Cu(OH)}_2 \xrightarrow{\Delta} \dots + \dots$

4- $2\text{Al} + \dots \longrightarrow \text{AlCl}_3 + \dots$

5- Mixtures are classified according to homogeneity into ,
.....

6- Nitric acid is used in industry while sulphuric acid is used in
..... industry.

7- Deficiency of hormone causes dwarfism.

2) Write (✓) in front of the correct statement, and (X) in front of the wrong ones :

1- Coulomb is the measuring unit of potential difference.

2- The acid is a solid substance.

3- Exophthalmia goiter is resulted due to thyroxin hormone defeciency.

4- The mutation always arises naturally.

5- In dry cell, magnetic energy is changed to electric energy.

6- Oxidation and reduction reactions take place separately.

7- Oxidation and reduction are two correlative processes and take place
at the same time.

General exercises on the Second term

3) Define each of the following :

- 1- Substitution reactions
- 2- Oxidation
- 3- Reduction
- 4- Oxidizing agent
- 5- Reducing agent
- 6- Rate of reaction
- 7- Reactants
- 8- Products
- 9- Catalysts
- 10- Electric current intensity
- 11- Coulomb
- 12- Electrical potential
- 13- Resistance
- 14- Ohm's law
- 15- Radioactivity
- 16- Mendel's first law
- 17- Mendel's second law
- 18- Mutation
- 19- Gametes
- 20- Gene
- 21- Endocrine glands

General exercises on the Second term

4) What would happen in each of the following cases

- 1- Pollination of peas flowers of hybrid yellow seeds with each other .
- 2- Exposure of human body to high radioactive doses for a short period of time.
- 3- Heating of red mercuric oxide.
- 4- Heating of copper sulphate.

5) Give reasons for each of the following :

- 1- Gold does not react with acids.
- 2- Catalyst is used in some chemical reactions.
- 3- Uranium is one of radioactive elements.
- 4- Mendel chose the pea plant to conduct his experiments.
- 5- Diabetes disease is treated with insulin hormone.
- 6- Pituitary gland is known as "master gland".

General exercises on the Second term

Answer the following questions:

1) Complete the following:

- 1- The process of losing an electron or more is called
- 2- In reactions, the compound is decomposed into its initial elements by heating.
- 3- Substance that gives oxygen or removes hydrogen is called
- 4- In the beginning of the reaction, the concentration of the reactants is %
- 5- Covalent compounds are in their reactions.
- 6- An excess of the solute cannot be dissolved in solution.
- 7- The rate of chemical reaction is by increasing the temperature.
- 8- The measuring unit of the quantity of electricity is
- 9- The measuring unit of the resistance of a conductor is
- 10- apparatus is used to measure the resistance in the circuit.
- 11- Chromosome is chemically composed of a nucleic acid called which is combined with
- 12- From types of mutation are and
- 13- hormone is secreted, when the percent of glucose sugar in the blood increased.
- 14- The speed of chemical reaction depends on , , and

General exercises on the Second term

15- Increasing of growth hormone secretion in the childhood stage causes

16- Deficiency of insulin hormone secretion causes

17- Dry cells produce current, while electric generators producecurrent.

18- Electric current is generated in dynamo as a result of change energy into energy.

19- Copper hydroxide is decomposed by heat to and

20- $\text{CuCO}_3 \xrightarrow{\Delta} \dots + \dots$

21- $2\text{Al} + 6\text{HCl} \longrightarrow 2\text{AlCl}_3 + \dots$

22- Nitric acid is used in industry while sulphuric acid is used in industry.

23- The deficiency of hormone secretion during stage causes the dwarfism.

24- From the factors that affect the rate of chemical reaction are , and

25- Chemical reaction is in the reactant molecules and in the product molecules.

26-acid is produced in human muscles during physical exercises.

27- Nuclear energy is used in medicine in and

General exercises on the Second term

2) Choose the correct answer for each of the following:

1- In thermal decomposition reactions, the compound is decomposed into

- a- its simple components
- b- its primary elements
- c- other compounds
- d- all the previous

2- On heating red mercuric oxide, it decomposes into

- a- oxygen
- b- mercury
- c- oxygen and mercury
- d- no correct answer

3- Heating of metal hydroxide produces

- a- metal oxide only
- b- metal oxide and CO_2
- c- CO_2 gas only
- d- no correct answer

4- Copper sulphate is decomposed by heat into

- a- black copper oxide only
- b- sulphur trioxide gas only
- c- sulphur dioxide gas and black copper oxide.
- d- black copper oxide and sulphur trioxide gas.

5- Some metal nitrates are decomposed by heat into

- a- metal nitrite and oxygen gas
- b- metal nitrate and oxygen gas
- c- nitrogen oxide and oxygen gas
- d- no correct answer

6- Blue copper hydroxide is decomposed by heat into

- a- copper oxide and oxygen
- b- copper oxide and water vapor
- c- copper and water vapor
- d- (a and c) are correct

7- The descending arrangement of metallic elements according to their chemical reactivity is called

- a- Chemical activity series
- b- (+ve) ions
- c- (-ve) ions
- d- free atoms

Exercise (3)

General exercises on the Second term

8- Active metals replace hydrogen of water and produce..... and hydrogen gas is evolved.

- a- metal hydroxide
- b- metal oxide
- c- metal carbonate
- d- metal sulphate

9- Active metals replace hydrogen of water producing metal hydroxide and gas is evolved.

- a- carbon dioxide
- b- hydrogen
- c- nitrogen
- d- oxygen

10- Metals replace hydrogen of the acid and gas is evolved.

- a- nitrogen oxide
- b- carbon dioxide
- c- hydrogen
- d- oxygen

11- Zinc reacts with dilute hydrochloric acid and salt is formed.

- a- zinc chloride
- b- zinc sulphate
- c- zinc nitrate
- d- no correct answer

12- Potassium reacts with dilute hydrochloric acid formingsalt.

- a- potassium nitrate
- b- potassium sulphate
- c- potassium chloride
- d- no correct answer

13- On adding copper turning to dilute hydrochloric acid is produced.

- a- copper hydroxide
- b- copper carbonate
- c- copper chloride
- d- no reaction

14- Some metals can replace another one in the solution of these metals which

- a- follow it in chemical activity series
- b- Precede it in chemical activity series
- c- (a and b) are correct
- d- no correct answer

General exercises on the Second term

15- When magnesium replaces copper in its salt solution, a precipitate is formed.

- a- black
- b- red
- c- reddish brown
- d- no correct answer

16- Double substitution reactions are classified into

- a- acid and alkali reaction
- b- reaction of an acid with a salt
- c- reaction of salt with another salt
- d- all the previous.

17- The acid reacts with an alkali producing

- a- salt and water
- b- salt and hydrogen gas
- c- salt and oxygen gas
- d- no correct answer

18- When potassium hydroxide reacts with hydrochloric acid are produced.

- a- potassium chloride and water
- b- potassium sulphate and water
- c- potassium oxide and water
- d- all the previous

19- Hydrochloric acid reacts with sodium carbonate powder forming

- a- sodium chloride and oxygen gas
- b- sodium chloride and CO_2 gas
- c- sodium oxide and water
- d- all the previous

20- Clear lime water turbids on passing gas through it.

- a- nitrogen dioxide
- b- sulphur dioxide
- c- carbon dioxide
- d- (a and b) are correct

21- $\text{Cu(OH)}_2 \xrightarrow{\Delta}$ +

- a- $\text{CuO} + \text{H}_2\text{O}$
- b- $\text{CuO} + \text{H}_2$
- c- $\text{Cu} + \text{H}_2\text{O}$
- d- no correct answer

Exercise (3)

General exercises on the Second term

d- all the previous



d- all the previous



26- When sodium chloride solution reacts with silver nitrate solution

a $\dots\dots\dots$ precipitate is formed.

a- red

b- white

c- reddish brown

d- blue

27- On passing hydrogen gas on hot copper oxide, a red precipitate of $\dots\dots\dots$ is formed.

a- copper

b- copper oxide

c- (a,b) are correct

d- all the previous

28- In the reaction of hydrogen with black copper oxide, $\dots\dots\dots$ process takes place to copper oxide.

a- oxidation

b- reduction

c- oxidation and reduction

d- no correct answer

General exercises on the Second term

29- The oxidizing agent is the substance that

- a- gives oxygen
- b- takes hydrogen
- c- (a and b) are correct
- d- no correct answer

30- The reducing agent is the substance that

- a- gives oxygen
- b- takes oxygen
- c- gives hydrogen
- d- (b and c) are correct

31- Reduction is a chemical process in which a decrease in the percentage of gas takes place.

- a- hydrogen
- b- oxygen
- c- chlorine
- d- carbon dioxide

32- Oxidation is a chemical process in which an increase in the percentage of gas.

- a- helium
- b- hydrogen
- c- oxygen
- d- fluorine

33- When sodium atom loses an electron from its outermost energy level, it becomes

- a- oxidized
- b- reducing agent
- c- reduced
- d- (a and b) are correct

34- From the factors that affect the rate of chemical reaction are

- a- concentration of the reactant
- b- nature of the reactant
- c- temperature
- d- all the previous

35- Iron fillings reacts with dilute hydrochloric acid faster than a piece of iron has the same mass due to the

- a- increase in concentration
- b- presence of a catalyst
- c- increase in surface area
- d- no correct answer

General exercises on the Second term

36- The rate of chemical reaction is increased by rising temperature due to

- a- increase the number of collisions between reactants.
- b- the presence of covalent bonds.
- c- increase of the surface area.
- d- no correct answer.

37- Catalyst increases the rate of chemical reaction, because it

- a- decreases the energy needed to start the reaction.
- b- combines with reactants then separates away to give the products .
- c- does not chemically change.
- d- all the previous.

38- At the beginning of the reaction, the percentage of the reactants concentration equals

- a- 100%
- b- 0%
- c- 50%
- d- no correct answer

39- The mixture in which solute molecules are distributed regularly through the solvent is called

- a- homogenous mixture
- b- heterogeneous mixture
- c- suspension
- d- no correct answer

40- The solution that an additional amount of the solute can be dissolve in it at certain temperature is called solution.

- a- unsaturated
- b- saturated
- c- suspension
- d- super saturated

41- The solution that no more solute can be dissolve in it without change in its temperature is known as solution.

- a- saturated
- b- unsaturated
- c- super saturated
- d- colloidal

General exercises on the Second term

42- The solution that allows more amount of solute to dissolve in it by increasing temperature is called solution.

a- saturated

b- unsaturated

c- super saturated

d- suspension

43- In manufacture of car batteries, acid is used.

a- phosphoric

b- hydrochloric

c- sulphuric

d- citric

44- The unit that is used in measuring electric resistance is

a- ohm

b- ampere

c- volt

d- coulomb

45- Electromotive force is measured in unit.

a- ohm

b- ampere

c- volt

d- joule

46- The **unit that is used in measuring electric current intensity is**

a- coulomb

b- ampere

c- volt

d- joule

Exercise (3)

General exercises on the Second term

47- The apparatus that is used in measuring electric current intensity is

- a- ammeter
b- voltmeter
c- ohmmeter
d- no correct answer

48- The apparatus that is used in measuring potential difference is

- a- voltmeter
b- ammeter
c- ohmmeter
d- rheostat

49- The apparatus that is used in measuring electric resistance is

- a- rheostat
b- ammeter
c- voltmeter
d- ohmmeter

50- The apparatus used to control the value of electric resistance in the circuit is

- a- ammeter
b- voltmeter
c- ohmmeter
d- rheostat

51- The mathematical relation of Ohm's law is

- a- $R = \frac{V}{I}$
b- $I = \frac{R}{V}$
c- $R = I \times V$
d- no correct answer

52- The unit that is used to measure the quantity of electricity passing through a circuit is

- a- volt
b- ampere
c- ohm
d- coulomb

53- To generate an alternating electric current, we use the

- a- rheostat
b- dynamo
c- ammeter
d- ohmmeter

General exercises on the Second term

54- To generate a direct electric current, we use the

- a- dry cell
- b- dynamo
- c- ammeter
- d- ohmmeter

55- Alternating current is characterized by

- a- constant intensity
- b- variable direction
- c- variable intensity and direction
- d- variable intensity

56- In dry cell, energy is converted to electrical energy.

- a- magnetic
- b- kinetic
- c- chemical
- d- light

57- In dynamo, energy is converted to electric energy.

- a- magnetic
- b- kinetic
- c- chemical
- d- light

58- Four similar electric cells, are connected in series ,each one has e.m.f of 1.5 volt so the total e.m.f equals volt.

- a- 3
- b- 6
- c- 1.5
- d- 12

59- The scientist who discovered radioactivity phenomena was

- a- Ohm
- b- Becquerel
- c- Ampere
- d- Mendel

60- The measuring unit of the absorbed radiation is

- a- Curie
- b- Rem
- c- Roentgen
- d- Ampere

Exercise (3)

General exercises on the Second term

61- The parts of DNA in the cell nucleus:

- a- gene
- b- gamete
- c- cytoplasm
- d- nor correct answer

62- It is chemically composed of the nucleic acid DNA combined with protein :

- a- cytoplasm
- b- chromosome
- c- gene
- d- no correct answer

63- The two factors of a hereditary trait are similar in the individual.

- a- pure
- b- hybrid
- c- recessive
- d- (a) and (c)

64- The hormone which stimulates body organs to respond for emergencies is

- a- insulin
- b- glucagon
- c- estrogen
- d- adrenalin

65- The hormone responsible for the appearance of the female secondary sex characters is

- a- estrogen
- b- testosterone
- c- parathormone
- d- insulin

66- The hormone responsible for the appearance of the male secondary sex characters is

- a- estrogen
- b- testosterone
- c- insulin
- d- thyroxin

General exercises on the Second term

67- The hormone which its deficiency causes the enlargement of the thyroid gland is

a- estrogen

b- insulin

c- thyroxin

d- glucagon

68- The hormone which stimulates the storage of glucose sugar in liver is the

a- insulin

b- estrogen

c- parathormone

d- thyroxin

69- The hormone which regulates the level of calcium in blood is the

a- calcitonin

b- thyroxin

c- adrenalin

d- progesterone

Exercise (3)

General exercises on the Second term

3) Mention one function only for each of the following :

- 1- Enzymes.
- 2- Refrigerator
- 3- Sulphuric acid.
- 4- Calcium carbonate.
- 5- Calcium oxide.
- 6- Catalyst (in chemical reaction).
- 7- Sodium Chloride.
- 8- Hydrochloric acid.
- 9- Silver nitrate.
- 10- Potassium nitrate.
- 11- Rheostat.
- 12- Radioactive elements in medicine.
- 13- Sodium and potassium salts in human body.
- 14- Voltmeter .
- 15- Adrenalin hormone in the human body.

General exercises on the Second term

4) Write a scientific term for each of the following :

- 1- A substance that loses one electron or more during a chemical reaction.
- 2- Process of breaking down the bonds between the molecules of reactants and formation of new bonds between the molecules of the products.
- 3- Reaction of an acid and a base to give salt and water.
- 4- Reaction involves replacing a metal by another one in its salt solution.
- 5- Change in the concentration of the reactants and products per unit time.
- 6- A substance that accelerates the rate of reaction and not participate in it.
- 7- Electric current intensity is directly proportional to potential difference between two terminals of a conductor at constant temperature.
- 8- An apparatus used to measure electromotive force.
- 9- The state of a conductor that determines the transfer of electricity from or to it.
- 10- The resistance that faces the electric current during its passage in a conductor.
- 11- The unit that is used to measure the absorbed radiation.
- 12- Spontaneous conversion of the atoms of some elements existing in nature, trying to reach a more stable structure.
- 13- Flow the electric charges through a conductor.
- 14- Through which , the hereditary traits are transmitted from parents to offspring.
- 15- When two homozygous individuals differ in one pair of contrasting characters are crossed, only the dominant trait appears in the first generation, and the two traits appear in the second generation by the ratio 3:1.

Exercise (3)

General exercises on the Second term

- 16- A structure consists of pentose sugar, a phosphate group and a nitrogenous base.
- 17- The changing of chemical composition of one gene or more.
- 18- Chemical substance regulates most human activities and functions.
- 19- Organs secrete hormones directly into blood stream.

5) Show by balanced chemical equations each of the following :

A- Effect of heat on:

- 1- Red mercuric oxide
- 2- Sodium nitrate
- 3- Copper hydroxide

B- Addition of water to:

- 1- Sodium metal

C- Effect of adding hydrochloric acid to:

- 1- Zinc metal
- 2- Sodium hydroxide

6) Rewrite the following statements after correcting the underlined words:

- 1- Rate of chemical reaction is increased by decreasing temperature.
- 2- Nitric acid is used in batteries industry.
- 3- Most of metals carbonate are decomposed into metal and carbon dioxide.
- 4- Electric current intensity is inversely proportional with potential difference at constant temperature.
- 5- The resistance of a conductor that 1 ampere is passed through it when the potential difference between its terminal is 1 volt equals 10 ohm.
- 6- In the electric cell, magnetic energy is converted into electrical energy.
- 7- When two individuals differ in two or more pairs of contrasting characters are crossed, each pair of characters is inherited together, and appear in second generation by the ratio 3:1.

General exercises on the Second term

- 8- The **acquired** traits are transmitted from a generation to another.
- 9- **Insulin** hormone is responsible for appearance of the human secondary male sex characters.
- 10- **Thyroid** gland secretes a hormone regulates the growth of human sex organs.
- 11- The **highfeed** is the mechanism by which hormones do their functions in human body.
- 12- **Iron element** participates in the composition of thyroxin hormone.

7) Compare between:

- 1- Ionic and covalent compounds (in the rate of reaction as a point of view).
- 2- Homogeneous mixture and heterogeneous one.
- 3- Saturated and unsaturated solutions.
- 4- Ammeter and Voltmeter (in terms of their uses and measuring units).
- 5- Alternating and direct current (in source and uses).
- 6- The mutation that occurs in reproductive cells and that occurs in somatic cells (according to their transmission from a generation to another).
- 7- Connecting electric cells in series and in parallel (in terms of the produced e.m.f)
- 8- The spontaneous mutation and induced one (in terms of their occurrence and controlling them).

General exercises on the Second term

8) What would happen when

- 1- Heating of sodium nitrate.
- 2- Putting a piece of sodium in water.
- 3- Putting a piece of magnesium in copper sulphate solution.
- 4- Exposing a man for a large dose of atomic radiation for a short period of time.
- 5- Chemical change of genes.
- 6- Heating of red mercuric oxide.
- 7- The deficiency of growth hormone secretion in childhood.
- 8- The deficiency of thyroxin hormone secretion.
- 9- Heating of blue copper hydroxide.

9) Give reasons for each of the following:

- 1- Sodium replaces hydrogen of the acids
- 2- Reactions of iron fillings with dilute hydrochloric acid is faster than its reaction with a piece of iron.
- 3- Rate of chemical reaction is increased by increasing the reactants concentration.
- 4- Radiation has genetic effects.
- 5- Alternating current is preferred than the direct one .
- 6- Rheostat is used in some electric circuits.
- 7- Mendel chose pea plant to conduct his experiments.
- 8- Copper does not react with dilute hydrochloric acid.
- 9- Pituitary gland is called "the master gland".
- 10- The region selected for saving radioactive wastes must be stable.

General exercises on the Second term

- 11- Diabetes disease is treated with insulin hormone.
- 12- Fridge is used in preservation of foods.
- 13- Pancreas is a doubled function gland.
- 14- Mendel covered the stigma of pea plant flowers during the study of hereditary traits.
- 15- The steel scourer used in cleaning aluminum burns more faster in a cylinder full of oxygen than its burning in air.
- 16- Some mutation do not transmit from a generation to another.
- 17- Calcium hydroxide is used in civil works.
- 18- Ionic compounds react faster than covalent ones.

10) State the contributions of the following scientists:

- 1- Ohm
- 2- Mendel
- 3- Watson and Creek
- 4- Henry Becquirel
- 5- Ali Mostafa Mosharafa

General exercises on the Second term

11) What is meant by each of the following ?

- 1- Reducing agent
- 2- Chemical reaction
- 3- Neutralization
- 4- Substitution
- 5- Rate of chemical reaction
- 6- Catalyst
- 7- Ohm's law
- 8- Voltmeter
- 9- Electric potential
- 10- Resistance
- 11- Rem
- 12- Radioactivity
- 13- Electric current
- 14- Genes
- 15- Mendel's first law
- 16- Nucleotide
- 17- Mutation
- 18- Hormone
- 19- Ductless glands (endocrines)
- 20- Gametes
- 21- Coulomb
- 22- Current intensity
- 23- Mendel's second law

General exercises on the Second term

12) Answer the following questions:

- 1- Calculate quantity of electricity when an electric current of intensity 18 ampere passes for 7 minutes through a conductor.
- 2- Calculate the electric current intensity when a quantity of electricity of 600 coulomb passes for 3 minutes in a conductor.
- 3- Calculate the potential difference between two points, if the work done to transfer a charge of 600 coulomb is 16600 Joule.
- 4- Calculate the e.m.f for a battery consists of 3 cells, the e.m.f for each 1.5 volt when they are connected :
 - a) In series
 - b) In parallel.
- 5- Calculate the potential difference between the terminals of an electric set its resistance is 30 ohm and the intensity of the passing electric current is 10 ampere.
- 6- Use the following symbols to express the results of mating between a short stemmed pea plant (tt) and a long stemmed pea plant (TT).

General exercises on the Second term

13) Put (✓) or (X) in front of each statement:

- 1- Fluoride ion is a negative ion as it loses an electron.
- 2- The ability to roll the tongue in a tube shape from the dominant trait in human.
- 3- Dwarfism is a continuous growth of human limb bones, so the person becomes a giant.
- 4- Hormones are secreted by the duct glands.
- 5- Nitric acid is used in batteries industry.
- 6- Dynamo produces an alternating electric current.

General exercises on the Second term

14) Mention the most important uses for each of the following:

- 1- Direct current
- 2- Ohmmeter
- 3- Ammeter
- 4- Alternating current
- 5- Sliding rheostat
- 6- Voltmeter
- 7- Folic acid
- 8- Calcium carbonate
- 9- Dry cell
- 10- Sodium nitrate
- 11- Dynamo
- 12- Nuclear energy in the space exploration field
- 13- Silver nitrate
- 14- Nuclear energy in the drilling field
- 15- Insulin hormone
- 16- Nuclear energy in agricultural field

Exams

Examination (1)

Answer the following questions:

Q1: A) Complete the following statements:

- 1- gland secretes hormone which controls the general growth of the body.
- 2- is used for measuring current intensity, while is used to measure potential difference.

B) Correct the underlined words

- 1- The fused ear pinna is a dominant hereditary trait.
- 2- Coulomb is used for measuring electromotive force.

Q2: A) Write a scientific term for the following statements

- 1- Chemical substances that control and regulate the function of most body organs.
- 2- Substance that gives oxygen and takes hydrogen.
- 3- The state of a conductor that allows the passage of electricity from or to it.

B) Explain each of the following:

- 1- Pituitary gland is called "the master gland"
- 2- On pollination of a red flowered pea plant with a white flowered pea plant, all offspring are red flowered.
- 3- Some mutation are not transmitted from a generation to another.

Exams

Q3 : Choose the correct answers:

1- Calcitonin hormone is secreted from

- a- pancreas
- b- thyroid gland
- c- pituitary gland
- d- adrenal gland

2- Which of the following characters is dominant in humans ?

.....

- a- Smooth hair
- b- Blue-coloured eyes
- c- Absence of freckles

Q4 :A) Compare between each pair of the following:

Saturated and super saturated solutions.

**B) What is meant by the principle of complete dominant
Give some examples.**

Exams

Examination (2)

Answer the following questions:

Q1: A) Choose the correct answers:

1-Heating of calcium carbonate produces.....

- a) calcium bicarbonate and carbon dioxide.
- b) calcium hydroxide and carbon dioxide.
- c) calcium oxide and carbon monoxide.
- d) calcium oxide and carbon dioxide.

2- The unit that is used in measuring electric resistance is

- a) ampere b) ohm c) volt d) coulomb

B) Give scientific explanation for each of the following:

- 1-Burning of the steel scoures used for cleaning aluminum in a jar full of oxygen is faster than its burning in atmospheric air.
- 2- The limbs bones of some people grow continuously, so they become giants.

C) What is meant by each of the following:

- 1- Diabetes.
- 2- Natural radioactivity.

Q 2: A) Draw a fully detailed diagram showing the feedback mechanism for homeostasis and maintaining the human blood sugar.

B) What is the difference between each pair of the following:

- 1- Induced and spontaneous mutations (in terms of their way of occurrence).
- 2- Physical , genetic and cellular effects resulted by radiation.

Exams

C) What would happen to ?

- 1- Blood sugar level, when pancreas does not secrete glucagon hormone.
- 2- Intensity of an electric current passing through a circuit, when the wire length of the sliding rheostat connected in this circuit is increased.

Q 3: A) Write the balanced chemical equations for the following reactions:

- 1- Addition of magnesium to copper sulphate solution.
- 2- Addition of zinc to dilute hydrochloric acid.
- 3- Heating of sodium nitrate.

B) Mention the following :

- 1- Mendel's first law
- 2- The law that is used to determine the value of an unknown resistance using electrical measurements.

C) Given three identical electric cells, the e.m.f. of each is 1.5 volt. Show by drawing how to connect them to produce:

- 1- A battery its e.m.f. is 1.5 volt.
- 2- A battery its e.m.f. is 3 volt.
- 3- A battery its e.m.f. is 6 volt.

Q 4: A) Calculate the quantity of electricity that passes in a conductor of a resistance 2200 ohm for two minutes when it is connected with a source of electric potential 220 volt.

B) What is the scientific ideas for?

- 1- The dominance of presence of cheek dimples over their absence.

C) What are the precautions on dealing with radioactive wastes ?

Exams

Examination (3)

Answer the following questions:

Q1: A) Choose the correct answer:

1- The hormone that controls calcium level in the blood is

a- calcitonin b- thyroxin c- insulin d- adrenalin

2- The potential difference is measured by using apparatus

a- ammeter b- ohmmeter c- voltmeter d-wattmeter

3- The substance that changes the rate of the reaction without itself being changed is known as ...

a- oxidizing agent b- reducing agent
c- active agent d- catalyst

B) Give reason for each of the following:

- 1- The stopping of body growth, so the person becomes a dwarf.
- 2- Calcium hydroxide is used in the civil works.

C) What is meant by each of the following:

- 1- The dominant trait.
- 2- Radioactive element

Q2: A) Draw a fully labeled diagram showing the relation between the secretion of the thyroid stimulating hormone and thyroxin hormone.

B) Write the difference between each pair of the following:

- 1- Connection of cells in series and in parallel (according to the resulted e.m.f.).
- 2- Spontaneous and induced mutations (in terms of the possibility to control them).

Exams

C) What would happen to ?

- 1- The human as thyroxin hormone secretion is increased.
- 2- Ammeter and voltmeter readings used in verifying Ohm's law if the resistance is burnet.

Q3: A) Write the balanced chemical equations for the following reactions:

- 1- Reduction of hot copper oxide by hydrogen.
- 2- Addition of hydrochloric acid to calcium hydroxide solution.
- 3- Placing aluminum turnings in dilute hydrochloric acid.

B) Mention each of the following:

- 1- Mendel's second law.
- 2- The two types of electric resistance.

Q4: A) Calculate the e.m.f of the battery in the opposite figure.

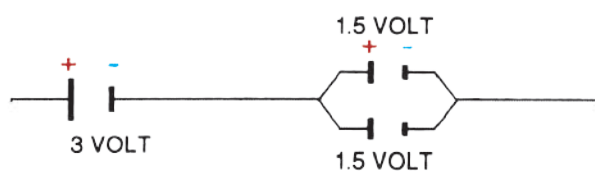

B) Draw the circuit used to deduce the relation between the intensity of an electric current passing through a resistance and the potential difference between its terminals.

C) Mutations vary according to several factors:

- 1- What are these factors ?
- 2- Briefly discuss one of these factors.

Exams

Examination (4)

Answer the following questions:

Q1: A) Complete the following statements:

- 1- When glucose level is increased in the blood, pancreas secretes hormone which stimulates the body to absorb..... from the blood.
- 2- Electric current intensity is measured by apparatus and its measuring unit is
- 3- The changing in nature of genes that control the organism's traits is known as
- 4- The resistance faces the flow of electric current in a conductor is known as

B) Give reasons for each of the following:

- 1- The usage of alternating current is preferred than the usage of the direct current.
- 2- Magnesium can replace copper in its salt solutions, while the opposite is impossible.

C) Give the scientific term for each of the following:

- 1- Chemical reactions in which double exchange of ions of two different compounds to produce two new compounds takes place.
- 2- The substance that takes oxygen or gives hydrogen during a chemical reaction.
- 3- The changing in concentration of the reactants and products per a unit time.

Q2: A) Compare between:

- 1- Solutions types.
- 2- Oxidation and reduction.

Exams

B) Show by drawing how electric cells are connected in:

1- Series 2- Parallel

**C) 10 coulomb was passed through a conductor of a resistance 22ohm.
Calculate the potential difference between its terminals.**

Q3: A) Draw an electric circuit used to verify Ohm's law, and state Ohm's law and its mathematical relation .

B) Write the balanced chemical equations for the following reactions:

1- Reaction of sodium with water and mention the precautions taken for this reaction.

2- Reaction of hydrochloric acid with sodium hydroxide, and mention the name of the reaction.

C) Mention the factors that affect the rate of a chemical reaction.

Q4: A) Mendel assumed a group of hypotheses to explain the appearance of the dominant trait and the disappearance of the recessive trait in the individuals of the first generation in the experiments he conducted on the pea plant. Explain these hypotheses.

B) State the scientific idea for each of the following:

1- The dominance of curly hairs on the smooth one.

2- Production of more larger and sweeter taste seedless fruits.

C) Explain the findings of the two scientists Watson and Creek of the structure of DNA molecule model.

Exams

Examination (5)

Answer the following questions:

Q1: Complete the following statements:

- 1- Red mercuric oxide decomposes by heat into and
- 2- $2\text{NaNO}_3 \xrightarrow{\Delta} \dots\dots\dots + \dots\dots\dots$
- 3- $\text{Zn} + 2\text{HCl} \rightarrow \dots\dots\dots + \dots\dots\dots$
- 4- The factors that affect the speed of chemical reaction are ,.....,..... and.....

Q2: A) Compare between:

- 1- Oxidizing and reducing agents.
- 2- Direct and alternating current.

B) Put (✓) in front of the correct statement, and (X) in front of the wrong ones :

- 1- Chloride ion has a negative charge as it loses an electron.
- 2- Dwarfism is the continuous growth of the limbs bones, so the person becomes a giant.
- 3- The ability to roll the tongue in a tube-form is one of the human dominant traits.

Q3: A) Explain an activity that illustrates:

- 1- Effect of temperature on the rate of a chemical reaction.
- 2- Determination the value of an unknown resistance.

B) What is meant by each of the following ?

- | | |
|-------------------|---------------------------|
| 1- Radioactivit . | 2- Heterogeneous mixture. |
| 3- Bases | 4- Induced mutation. |

Exams

Q4: A) Show by drawing the method used for:

- 1- Connection of three cells in series and also in parallel.
- 2- Determination the potential difference between the terminals of an electric lamp.

B) Give reason for:

- 1- Learn to walk in children is not considered a genetic trait.
- 2- Red precipitate is formed on addition of magnesium to copper sulphate solution.

Exams

Examination (6)

Answer the following questions:

Q1: Complete the following statements:

- 1- Chemical reaction is a process involves in reactants molecules and formation of in products molecules.
- 2- $\text{CuSO}_4 \xrightarrow{\Delta} \dots\dots\dots + \dots\dots\dots$
- 3- acid is produced in human body during physical exercises.
- 4- Nuclear energy is used in medicine in.....and.....

Q2: Compare between :

- 1- Oxidation and reduction.
- 2- Ammeter and voltmeter.

Q3: A) Put sign (✓) in front of the correct statement, and (X) in front of the wrong ones :

- 1- Sodium ion is positive (Na^+) as it gains an electron.
- 2- Mutation vary according to their sites of occurrence, inheritance and origin.
- 3- Hormones are secreted from duct glands.

B) Calculate the current intensity resulted when a quantity of electricity of 6000 coulomb is passed in a conductor for 10 minutes.

Q4: A) Explain an activity that illustrates:

- 1- Effect of surface area on the rate of chemical reaction.
- 2- Verifying of Ohm's law practically.

Exams

B) Define each of the following:

- 1- Homogenous mixture.
- 2- Super saturated solution.
- 3- Acids
- 4- Potential difference.

Model answer for general exercises on the 2nd term School book Page 96 (3rd prep)

1- Choose:

1. B
2. A
3. D
4. B
5. A

2- Give reason:

1. Because iron fillings with greater surface area so the speed of the reaction increases.
2. Because the oxygen gas with higher concentration so the collision between molecules increases leading to the increase in the speed of the chemical reaction.
3. Due to precipitation of copper because it is replaced by magnesium as it is more active than copper.

3- Compare between:

1- Oxidation	Oxidizing agents
It is a chemical process which causes the increase of the oxygen percentage or the decrease of hydrogen percentage.	It is the substance which gives oxygen or takes hydrogen away during chemical reactions.

2- Testes	Ovaries
Secrete Testosterone hormone. Responsible for the appearance of the male secondary sex characters	a. Estrogen hormones: responsible for appearance of female secondary sex characters b. Progesterone hormones: it promotes the growth of endometrium.

3- Dominant trait	Recessive trait
It is pure or hybrid.	It is always pure.

4- Complete:

1. Copper.
2. Silver chloride.
3. DNA

5- Chemical reactions are classified into different types, write the type of each reaction of the following

1. Oxidation and reduction reaction.
2. Double substitution reaction.
3. Simple substitution reaction.

6- Define each of the following:

1. Electric current intensity: it is the quantity of charges passing through across section area of the conductor in one second.
2. Ammeter: it is the device that is used to measure the current intensity and it is connected to the circuit in series.
3. Electric potential: It is the condition of an electric conductor that shows the transfer of the electricity to and from it when it is connected to another conductor.
4. Volt: it is the potential difference across two terminals of a conductor on doing a work of 1 joule to transfer a quantity of charge of 1 coulomb.
5. Electric resistance: It is the obstructions that the electric current faces during its movement through the conductor.
6. Ohm: is the resistance of the conductor that has an electric current passing through it, of intensity of 1 Ampere and when the potential difference between its terminals is 1 Volt.
7. Acquired characters: they are the traits that aren't transmitted from one generation to another.
8. Mutation; it is a change in the nature of the hereditary factors that control the traits of a living organism which results in a change in the living organism's traits.
9. Hormone: it is a chemical substance that controls and organises most of the vital activities and functions in the bodies of the living organisms.

7- Mention each of the following:

1. A. radioactive wastes should be away from underground water's path.
B. area chosen for storing radioactive wastes should be a steady one and away from animals that lives in caves.

2. A. Not to be exposed to the maximum safe doses of nuclear radiation (5rem)
 B. wear radiation protective gloves, clothes and masks.
 C. establish laws for nuclear plants to cool the hot water before throwing it in seas and lakes.
3. The hereditary traits in a living being is represented by two hereditary factors segregated from each other when the gametes are formed where the gamete carries one hereditary factor to each trait
4. Diabetes.
5. The spontaneous conversion of the atom's nuclei of some elements that are present in nature in an attempt to achieve a more stable composition, where the atom nuclei of these elements contain a number of neutrons more than the number required for its stability.
6. Ohm's law: The **current** flowing through a metal conductor is **directly proportional** to the **potential difference** across it at constant temperature.

8- Solution:

$V = 6\text{volts}$ $I = 0.5\text{ amp}$

$I = ?$ $V = 12\text{ volts}$

$R = V/I = 6/0.5 = 12\text{ ohm}$

$I = V/R = 12/ 12 = 1\text{ amp.}$

9- Solution:

$q = ?$ $R = 1000\text{ Ohm}$ $t = 30\text{min}$ $V = 220\text{ volts}$

$I = q / t = V/ R$

$q = V \times t / R = 220 \times 30 \times 60 / 1000 = 396\text{ coulomb}$

10- Solution:

1. Battery of emf 1.2 volts

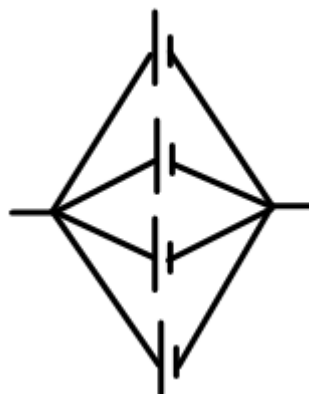

2. Battery of emf 4.8 volts

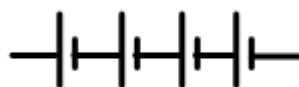

3. Battery of emf 2.4

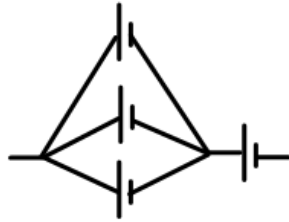

Page 99

11- Choose

1. Ampere – Ammeter
2. Volt – Voltmeter
3. Ohm – Ohmmeter.

12- 1. Treatment and diagnosis of tumors.

2. killing pests.

3. Changing sand into silicon.

4. Changing water into steam to operate electric generators.

13- Exposure to radiations like X- rays , exposure to high or low temperature or exposure to chemical substances.

14- 1.

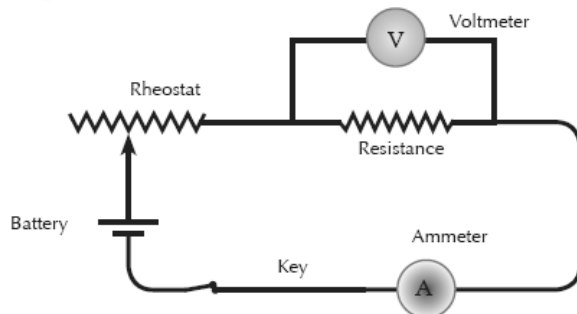

2.

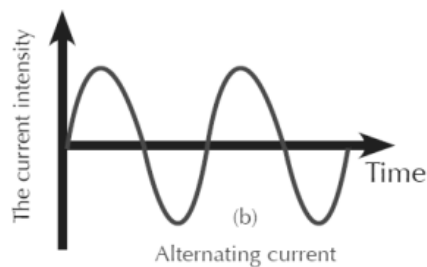

15- Compare

Industrial uses of bases	Industrial uses of salts
<ul style="list-style-type: none"> • Calcium hydroxide {Ca(OH)₂} is used in: <ol style="list-style-type: none"> 1. The civil works as in the preparation of the cement mixture. 2. In water treatment. 3. The reduction of soil acidity. 	<ul style="list-style-type: none"> • Calcium carbonates are used in: glass and cement manufactures. • Potassium nitrates are used in: the manufacture of explosives and fertilizers. • Silver nitrates are used in: the manufacture of sensitive camera films.

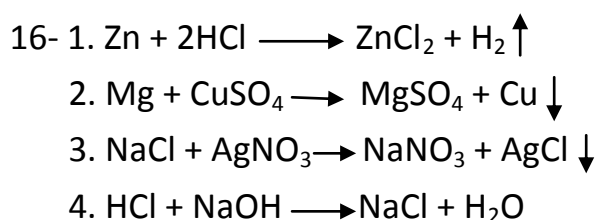

Page 100

- 17- 1. 2HgO
 2. 2NaNO₂
 3. HCl

- 18- 1. Because the reactions of ionic compounds take place between ions while that of covalent compounds take place between molecules.
 2. Due to the increase in the collisions between molecules so the speed of the reaction increases.
 3. Due to decrease of secretion in the growth hormone at the childhood.

19- Compare

Point of comparison	Direct current	Alternating current
1- Definition	It is the current that is produced from electric cell and it has constant intensity and one direction.	It is the current that is produced from electric generator and has variable intensity and direction.
2- Uses	<u>Used in:</u> 1. Electroplating. 2. Electrolysis process. 3. Operating of some electric machines.	<u>Used in:</u> 1. Lighting houses. 2. Operating electric applications

20- 1. Medical field: To treat and diagnose diseases like cancer.

Agricultural field: To eliminate pest and improve some plants.

2. Sodium bicarbonate is used in polishing silver and any decorative pieces made of copper or chrome.

3. **Calcium hydroxide** $\{Ca(OH)_2\}$ is used in: as in the preparation of the **cement** mixture, In water treatment and in the reduction of soil acidity.

21-

Substance (acid – base – salt)	Economic importance
Stomach acid	Digestion of proteins
Calcium carbonate	Manufacture of glass and cement
Magnesium hydroxide	Antacids
Potassium nitrate	Explosives and fertilizers
Silver nitrate	Sensitive photographic films.

Page 101:

1- Complete:

1. Ammonium nitrite, oxygen
2. $CuO + CO_2$
3. $CuO + H_2O$
4. $6HCl, 3H_2$
5. Homogenous, heterogeneous.
6. Fertilizers, car batteries.
7. Growth.

2- Put \checkmark or X:

1. X
2. X
3. X
4. X
5. X
6. X
7. \checkmark

3- Define:

1. They are the reactions that depend on the activity of the metals, where the element which is more active replaces the less active one in another compound.
2. It is a chemical process which causes the **increase** of the **oxygen** percentage or the **decrease** of **hydrogen** percentage.
3. It is a chemical process which causes the **decrease** of the **oxygen** percentage or the **increase** of **hydrogen** percentage.
4. It is a chemical process which causes the **decrease** of the **oxygen** percentage or the **increase** of **hydrogen** percentage.
5. It is a chemical process which causes the **decrease** of the **oxygen** percentage or the **increase** of **hydrogen** percentage.
6. It is the change in the concentration of reactants and products at a unit of time.
7. The substance that react with each other in the reaction.
8. The products of the chemical reaction.
9. It is a substance that speeds up the chemical reaction without changing or being used up.
10. It is the quantity of electric charges flowing through a cross section of the conductor in 1 sec.
11. **Coulomb**: it is the charge transferred by constant current of 1 ampere in 1 sec.
12. It is the condition of an electric conductor that shows the transfer of the electricity to and from it when it is connected to another conductor.
13. It is the condition of an electric conductor that shows the transfer of the electricity to and from it when it is connected to another conductor.
14. The **current** flowing through a metal conductor is **directly proportional** to the **potential difference** across it at constant temperature.
15. The radioactivity phenomenon is known as the spontaneous conversion of the atom's nuclei of some elements that are present in nature in an attempt to achieve a more stable composition, where the atom nuclei of these elements contain a number of neutrons more than the number required for its stability.
16. When two individuals of any pair of hereditary traits are different from each other, only the dominant trait appears in the first generation, while the two traits appear in the second generation in ratio 3 dominant : 1 recessive.
17. When two individuals bearing a pair or more of contrasting traits are crossed, the trait of each pair is inherited independently of the other and appears in the second generation at a ratio of 3:1.
18. It is the change in the nature of the hereditary factors that controls the traits of a living organism which results in a change in the living organism's traits.
19. These are the reproductive cells that carry the hereditary factors.

20.They are part of DNA and they are responsible for the appearance of the inherited traits.

21.They are ductless glands that secrete their hormones directly in the blood without passing through ducts.

Page 103

4- What would happen?

1. The first generation will be: 50% yellow and 50% green.
2. Leads to damage of: Bone marrow. Spleen. Digestive system. Central nervous system.
3. Thermal decomposition and formation of silver mercury and oxygen gas evolves.
4. Formation of black copper oxide and sulphur trioxide evolves.

5- Give reason:

1. Because according to the chemical activity series, gold is less active than hydrogen so it can't replace it in its acid.
2. To change the speed of the chemical reaction either increases it by positive catalyst or decreases it by negative catalyst.
3. Because its atom's nuclei contain a number of neutrons more than the number required for its stability.
4. Because it has short life cycle, grows fast, hermaphrodite, produces large number of offspring and with many contrasting traits.
5. Because it occurs due to deficiency in insulin hormone leading to increase in the level of sugar in blood.
6. Because it secretes hormones that regulate the activities of other endocrine glands.

Page 104

1- Complete:

1. Oxidation.
2. Thermal decomposition.
3. Oxidizing agent.
4. 100%
5. Slow.
6. Saturated solution.
7. Increased.
8. Coulmb.

9. Ohm.
10. Ohmmeter.
11. DNA, protein.
12. Spontaneous mutation, induced mutation.
13. Insulin.
14. Nature of the reactants, concentration of the reactants, temperature of the reaction, catalyst.
15. Gigantism.
16. Diabetes.
17. Direct, alternating.
18. Mechanical energy, electric energy.
19. Copper oxide, water.
20. CuO, CO₂
21. 3H₂
22. Manufacture of fertilizers, car batteries.
23. Growth, childhood.
24. Catalyst, concentration of the reactants, temperature of the reaction.
25. Breaking of bonds, formation of new bonds
26. Lactic acid.
27. Diagnosis and treatment of cancer.

Page 106

2- Choose:

1. D
2. C
3. D
4. D
5. A
6. B
7. A
8. A
9. B
10. C
11. A
12. C

13.D
14.A
15.C
16.A, b
17.A
18.A
19.B
20.C
21.A
22.B
23.A
24.C
25.A
26.B
27.A
28.C
29.A
30.B
31.B
32.C
33.D
34.D
35.C
36.A
37.D
38.A
39.A
40.A
41.A
42.C
43.C
44.A
45.C
46.B
47.A

48.A
49.D
50.D
51.A
52.D
53.B
54.A
55.C
56.C
57.B
58.B
59.B
60.B
61.A
62.B
63.D
64.D
65.A
66.B
67.C
68.A
69.A

Page 117

3- Mention one function

1. They control the digestion of food.
2. Preservation of food.
3. Manufacture of car batteries.
4. Manufacture of glass and cement.
5. Water treatment.
6. Increasing the rate of some chemical reactions.
7. Salting and preservation of food.
8. Manufacture of detergent.
9. Manufacture of sensitive photographic films.
10. Manufacture of fertilizers and explosives.
11. Changing current intensity and potential difference in electric circuit.

12. In treatment and diagnosis of cancer.
13. Transfer of nerve impulses.
14. Used to measure potential difference and emf.
15. Stimulates body's organs to respond to emergencies.

Page 118

4- Write the scientific term:

1. Reducing agent.
2. Chemical reactions.
3. Neutralization reaction.
4. Substitution reaction.
5. Speed of chemical reaction.
6. Catalyst.
7. Ohm's law.
8. Voltmeter.
9. Electric potential.
10. Ohm.
11. Rem.
12. Radioactive phenomenon.
13. Electric current.
14. Gametes.
15. Mendel's 1st law.

Page 119

16. Nucleotide.
17. Genetic mutation.
18. Hormones.
19. Endocrine glands.

6- Rewrite the statements after correcting the underlined word:

1. Increasing
2. Sulphuric acid
3. Metal oxide
4. Directly
5. 1ohm
6. Chemical.
7. Independently.

8. Hereditary.
9. Testosterone.
10. Pituitary.
11. Feedback.
12. Iodine.

7- Compare between:

1- Ionic compound	Covalent compound
High rate of chemical reaction.	Low rate of chemical reaction.

2-Points of comparison	Homogeneous	Non- Homogeneous
Define	It is the mixture in which the solute molecules are distributed in the solvent in a regular way in all its parts.	It is the mixture in which the solute molecules are distributed in the solvent in an irregular way in all its parts.
Solute molecules	Can't be distinguished	Can be distinguished
Example	Sugar solution. Salt solution.	Water and oil. Water and sand.

3- Unsaturated solution	Saturated solution
It is the solution in which an additional amount of the solute can be added at a certain temperature. (The solvent has the ability of dissolving another amount of the solute).	It is the solution in which no additional amount of the solute can be added without the change in temperature. (The number of dissolved molecules is equal to the number of the precipitated molecules).

4- Ammeter	Voltmeter
Used to measure current intensity.	Used to measure potential difference and emf.
Measuring unit ampere.	Measuring unit volt.

5-Points of comparison	Direct electric current	Alternating electric current
Sources	Electrochemical cells (Batteries)	Electric generators (Dynamamos)
Uses	Used in: 1. Electroplating. 2. Electrolysis process. 3. Operating of some electric machines.	Used in: 1. Lighting houses. 2. Operating electric applications

6- Somatic mutation	Reproductive cell mutation
in somatic cells, they affect on the individual and not transmitted from one generation to another. (not inherited)	in reproductive cells, they are transmitted from one generation to another. (inherited)

7- Connection in series	Connection in parallel
Produced emf = sum of emf of electric cells	Produced emf = emf of one electric cell only.

8- Spontaneous mutation	Induced mutation
It occurs without the effect of man (naturally) and not controlled by man	It occurs by man under his control .

Page 121

8- What would happen when?

1. Formation of sodium nitrite and oxygen gas evolves.
2. It will burn with pop sound. Sodium hydroxide is formed and hydrogen gas evolves.
3. Magnesium sulphate will be formed and precipitation of reddish brown copper.
4. Leads to damage of: Bone marrow. Spleen. Digestive system. Central nervous system.
5. Leads to genetic mutation and formation of different protein leading to appearance of new trait.
6. Thermal decomposition occurs producing mercury and oxygen gas evolved.
7. Dwarfism.
8. Simple goitre.
9. Formation of black copper oxide and water.

9- Give reason:

1. Because according to the chemical activity series, sodium is more active than hydrogen.
2. Because iron fillings with greater surface area.
3. Due to the increase in the number of collisions between the molecules of the reactants and so the speed of the reaction increases.
4. Because it can change the composition of sex chromosomes leading to abnormal birth.
5. Because it can be transmitted to long distance, can be converted into direct current and it is used in operating many electric applications.
6. To change the current intensity and the potential difference in the electric circuit.
7. Because it has short life cycle, grows fast, hermaphrodite, produces large number of offspring and with many contrasting traits.
8. Because it is less active than hydrogen.
9. Because it secretes hormones that regulate the activities of other endocrine glands.
10. To prevent the spread of radiation to other areas.

Page 122

11. Because it reduces the percentage of glucose sugar in blood.
12. Because it has greater surface area so it increases the rate of the reaction.
13. As it decreases the temperature so it decreases the rate of the reaction of bacteria in the food.
14. Because the pancreas secretes the insulin and glucagon hormones and it also secretes digestive enzymes that help in digestion process.
15. In order not to cross pollination from other flowers.
16. Due to the high concentration of oxygen gas in the cylinder.
17. Because some mutations take place in the somatic cells that are not transmitted to the offspring.
18. Because it is used in the manufacture of cement.
19. Because the reactions of ionic compounds take place between ions while that of covalent compounds take place between molecules.

10- State the contributions of the following scientists:

1. He found the relation between potential difference, current intensity and the resistance in the electric circuit by Ohm's law $R = V/I$
2. He is the founder of heredity and has two laws: Mendel's 1st law or law of segregation of hereditary factors and Mendel's 2nd law or law of independent assortment of hereditary factors.

3. They made a model for DNA (double helix)
4. He discovered the radioactive phenomenon.
5. He has many theories about the nuclear energy.

Page 123

11- What is meant by?

1. It is the substance which **loses an electron or more** during chemical reaction.
2. It is the breaking of bond in the reactants and formation of new bond in the molecules of the products
3. Reaction between acid and base to give salt and water.
4. They are the reactions that depend on the activity of the metals, where the element which is more active replaces the less active one in another compound.
5. It is the change in the concentration of reactants and products at a unit of time.
6. It is a substance that speeds up the chemical reaction without changing or being used up.
7. The **current** flowing through a metal conductor is **directly proportional** to the **potential difference** across it at constant temperature.
8. Device used to measure the potential difference and emf.
9. It is the condition of an electric conductor that shows the transfer of the electricity to and from it when it is connected to another conductor.
10. It is the opposition that the electric current faces during its passing through a conductor.
11. It is the measuring unit for radiation absorbance.
12. The radioactivity phenomenon is known as the spontaneous conversion of the atom's nuclei of some elements that are present in nature in an attempt to achieve a more stable composition.
13. It is the flow of electric charges through a conductor.
14. They are part of DNA and they are responsible for the appearance of the inherited traits.
15. When two individuals of any pair of hereditary traits are different from each other, only the dominant trait appears in the first generation, while the two traits appear in the second generation in ratio 3 dominant: 1 recessive.
16. The gene consists of smaller blocks called nucleotides that consist of phosphate group, deoxyribose sugar and nitrogenous base.
17. It is the change in the nature of the hereditary factors that controls the traits of a living organism which results in a change in the living organism's traits.

18. Chemical substances secreted by special cells in the body that work with the nervous system to organize and coordinate both activities and functions of organs of living organisms.
19. These are ductless glands that secrete hormones directly into the blood stream.
20. They are reproductive cells that carry the hereditary factors.
21. It is the charge transferred by constant current of 1 ampere in 1 sec.
22. It is the quantity of electric charges flowing through a cross section of the conductor in 1 sec.
23. When two individuals bearing a pair or more of contrasting traits are crossed, the trait of each pair is inherited independently of the other and appears in the second generation at a ratio of 3:1.

Page 124

12- Answer the following questions:

1. $q = ?$ $I = 18 \text{ amp.}$ $t = 7 \text{ min} = 420 \text{ sec.}$
 $q = I \times t = 18 \times 420 = 7560 \text{ coulombs.}$
2. $I = ?$ $q = 600 \text{ col.}$ $T = 3 \text{ min} = 180 \text{ sec.}$
 $I = q/t = 600/180 = 3.33 \text{ amp.}$
3. $V = ?$ $W = 16600 \text{ Joule}$ $q = 600 \text{ col.}$
 $V = W/q = 16600/600 = 27.67 \text{ volts}$
4. a. $\text{emf} = 3 \times 1.5 = 4.5 \text{ volts}$
 b. $\text{emf} = 1.5 \text{ volts.}$
5. $V = ?$ $R = 30 \text{ Ohm}$ $I = 10 \text{ amp.}$
 $V = I \times R = 10 \times 30 = 300 \text{ volts.}$
- 6.

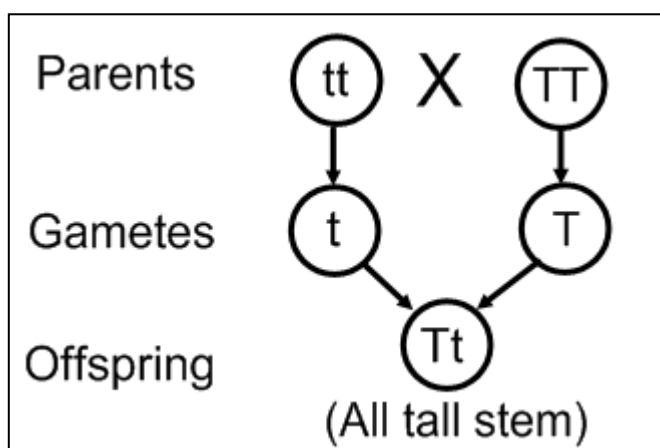

13- Put \checkmark or X

1. X (volt)
2. X (liquids)
3. X (simple goitre)
4. X (induced or natural)
5. X (alternating current)
6. X (together)
7. X (gains)
8. \checkmark

Page 125

9. X (Gigantism)
10. X (ductless)
11. X (sulphuric acid)
12. \checkmark
13. \checkmark
14. X (not transmitted)
15. X (spontaneous)
16. X (Watson and Creek)
17. X (growth hormone)
18. \checkmark

Page 126

14- Mention the important uses for each of the following:

1. Used in electroplating and electrolysis.
2. Used to measure the resistance in the electric circuit.
3. Used to measure the current intensity.
4. Hydrogenation of oils.
5. Used in lightening houses and in operating electric appliances.
6. Used to change the current intensity and potential difference in electric circuit.
7. Used to measure the potential difference and emf.
8. Necessary for proper growth of cells.
9. Used in manufacture of glass and cement.
10. Used to change chemical energy into electric energy.
11. Used in making fertilizers.
12. Used to change mechanical energy into electric energy.

13. Used as fuel for space rockets.
14. Silver nitrate: manufacture of sensitive photographic films.
15. Used for drilling of petroleum and underground water.
16. Stimulates the storage of glucose sugar in liver.
17. Eliminate pest and improve some plants.

Page 135

Examination 1

Q 1: A- Complete:

1. Pituitary, growth.
2. Platinum, palladium.
3. Ammeter, voltmeter.

B- Correct:

1. Free.
2. Volt.

Q2: A- Write the scientific term:

1. Hormones.
2. Oxidizing agent.
3. Electric potential.

B- Explain:

1. It secretes hormones that regulate the activities of other endocrine gland.
2. As the red flower colour is the dominant trait over the white flower colour.
3. As somatic mutation is not inherited to the offspring.

Q3: Choose:

1. B
2. C

Q4: A- Compare:

Saturated solution	Super saturated solution
It is the solution in which no additional amount of the solute can be added without the change in temperature. (The number of dissolved molecules is equal to the number of the precipitated molecules).	It is the solution which accepts the dissolution of an additional amount of the solute with the increase in temperature (the amount of the solute is greater than in the case of the saturated solution).

B- Complete dominance

It is the appearance of a dominant hereditary trait in the individuals of the first generation when two individuals are crossed, one of them carries a pure trait contrasting the trait carried by the other individual.

Example : crossing between short stem pea plant (tt) and tall stem pea plant (TT)

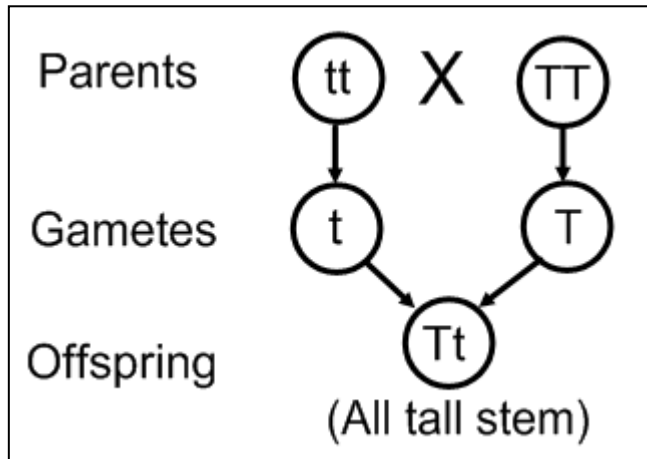

Page 137

Examination 2

Q1: A- Choose

1. D
2. B

B- Give scientific explanation

1. Due to the presence of higher concentration of oxygen in the cylinder.
2. Due to the increase in the secretion of growth hormone during childhood.

C- What is meant by?

1. It is a disease due to the decrease in the secretion of insulin hormone, the cells are unable to use glucose.
2. It is the radiation produced from natural radioactive elements present in nature.

Q2: A

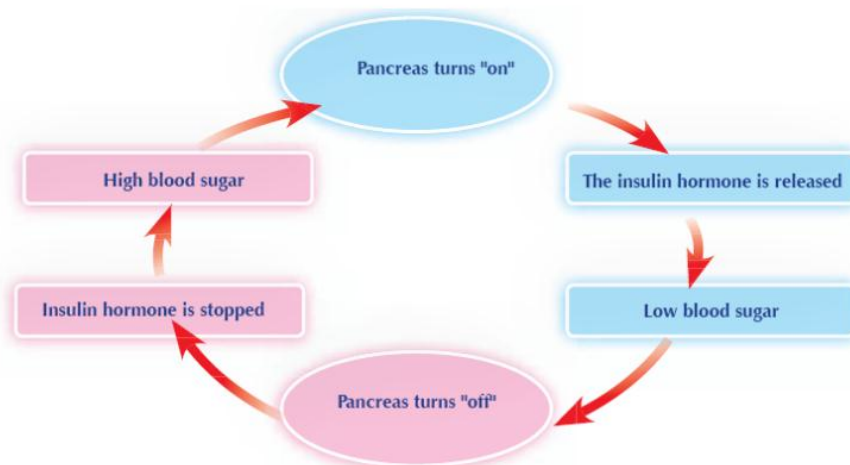

B- What is the difference between?

1- Spontaneous mutation	Induced mutation
It occurs without the effect of man (naturally) and not controlled by man	It occurs by man under his control .

2-

- a. **Physical effects:** Changes appear on living organisms.
- b. **Genetic effects:** Changes in sex chromosomes in the cell leading to abnormal birth.
- c. **Cellular effects:** Changes in cell composition that lead to cell destruction.

C- What would happen to?

1. The glucose stored in the liver won't be released in the blood stream leading to decrease in the sugar level in the blood.
2. The current intensity will decrease.

Q3: A- Write chemical equation:

1. $\text{Mg} + \text{CuSO}_4 \longrightarrow \text{MgSO}_4 + \text{Cu}$
2. $\text{Zn} + 2\text{HCl} \longrightarrow \text{ZnCl}_2 + \text{H}_2$
3. $2\text{NaNO}_3 \xrightarrow{\Delta} 2\text{NaNO}_2 + \text{O}_2$

B- Mention

1. When two individuals of any pair of hereditary traits are different from each other, only the dominant trait appears in the first generation, while the two traits appear in the second generation in ratio 3 dominant: 1 recessive.
2. Ohm's law : $R = V/I$

The **current** flowing through a metal conductor is **directly proportional** to the **potential difference** across it at constant temperature.

C-

1.

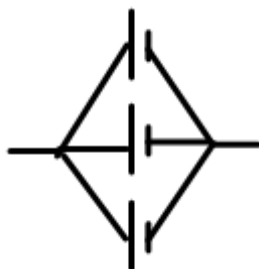

2.

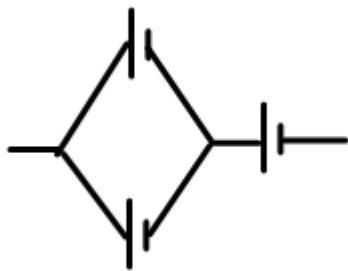

3.

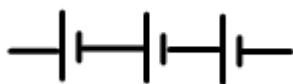

Q4: A- $q = ?$ $R = 2200 \text{ ohm}$ $t = 2 \text{ min} = 120 \text{ sec.}$ $V = 220 \text{ volts}$

$$I = V / R = 220 / 2200 = 0.1 \text{ amp.}$$

$$q = I \times t = 0.1 \times 120 = 12 \text{ coulomb}$$

B- What is the scientific idea of?

1. They are designed such that they get inflated at an extreme speed on the occurrence of car crash, where rapid decomposition and explosion happen to sodium azide forming sodium and nitrogen gas evolves which fills the air bag.

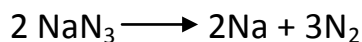

2. The gene of the presence of facial dimples dominates over the gene of the absence of facial dimples, if they are both present in an individual.

C-

- a. These radioactive wastes should be away from underground water's path so it will not get polluted.
- b- The area chosen for storing the radioactive waste should be a **stable** one and not exposed to earthquakes or volcanoes.
- c- The area chosen for storing the radioactive waste should be **away** from the animals that live in caves so it will not be exposed to the danger of radiation produced by the wastes and in turn this danger reaches other living beings.

Examination 3

Q1: A- Choose

1. A
2. C
3. D

B- Give reason

1. Due to deficiency in growth hormone during childhood.
2. As it is used in manufacture of cement.

C- What is meant by?

1. It is the trait that appears in all individuals of the first generation.
2. They are elements whose atom's nuclei contain number of neutrons More than the number required for its stability.

Q2: A- Draw

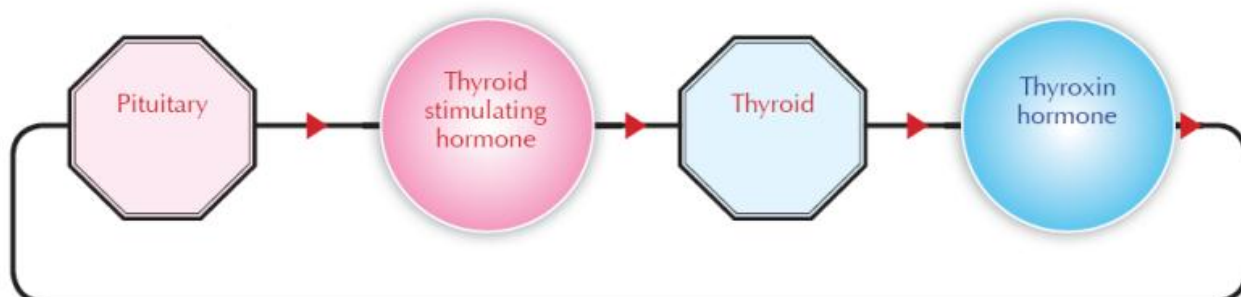

B- Write the difference

1- Connection in series	Connection in parallel
Produced emf = sum of emf of electric cells	Produced emf = emf of one electric cell only.

2- Spontaneous mutation	Induced mutation
It occurs without the effect of man (naturally) and not controlled by man	It occurs by man under his control .

C- What would happen to?

1. He will suffer from exophthalmic goitre.
2. They won't give any reading and ohm's law is not verified.

Q3- A- Write balanced chemical equations:

1. $\text{CuO} + \text{H}_2 \xrightarrow{\Delta} \text{H}_2\text{O} + \text{Cu}$
2. $2\text{HCl} + \text{Ca}(\text{OH})_2 \longrightarrow \text{CaCl}_2 + 2\text{H}_2\text{O}$
3. $2\text{Al} + 6\text{HCl} \longrightarrow 2\text{AlCl}_3 + 3\text{H}_2$

B- Mention

1. When two individuals bearing a pair or more of contrasting traits are crossed, the trait of each pair is inherited independently of the other and appears in the second generation at a ratio of 3:1.
2. Variable resistance (rheostat)
Fixed resistance.

Q4- A- emf = 4.5 volts

B-

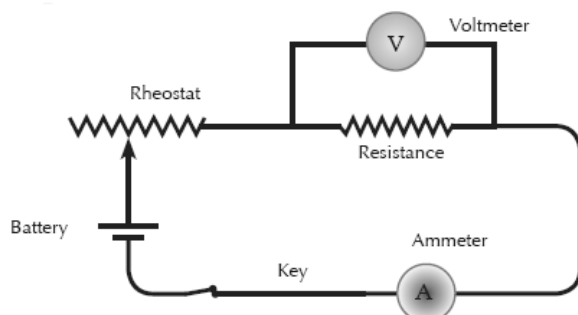

C- 1. Site, origin and inheritance.

2. **Its inheritance:**

- a. **Somatic mutation:** in somatic cells, they affect on the individual and not transmitted from one generation to another. **(not inherited)**
- b. **Gamete mutation:** in reproductive cells, they are transmitted from one generation to another. **(inherited)**

Examination 4

Q1: A- Complete:

1. Insulin, sugar.
2. Ammeter, ampere.
3. Mutation.
4. Electric resistance.

B- Give reason:

1. Because it can be transmitted to long distance, can be converted into direct current and it is used in operating many electric applications.
2. Because magnesium is more active than copper.

C- Give the scientific term:

1. Double substitution reaction.
2. Reducing agent.
3. Speed of chemical reaction.

Q2: A- Compare

1-Unsaturated solution	Saturated solution	Super saturated solution
It is the solution in which an additional amount of the solute can be added at a certain temperature. (The solvent has the ability of dissolving another amount of the solute).	It is the solution in which no additional amount of the solute can be added without the change in temperature . (The number of dissolved molecules is equal to the number of the precipitated molecules).	It is the solution which accepts the dissolution of an additional amount of the solute with the increase in temperature (the amount of the solute is greater than in the case of the saturated solution).

2- Oxidation	Reduction
It is a chemical process which causes the increase of the oxygen percentage or the decrease of hydrogen percentage.	It is a chemical process which causes the decrease of the oxygen percentage or the increase of hydrogen percentage.

B- 1- Series



2- Parallel

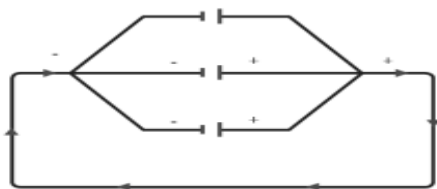

C- $q = 10$ coulomb $R = 22$ Ohm $V = ?$ (wrong problem : time must be given)

Q3: A- Draw

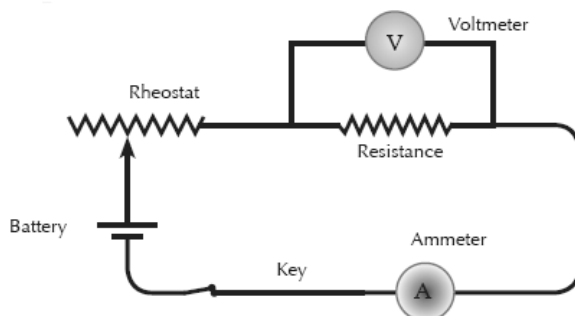

The **current** flowing through a metal conductor is **directly proportional** to the **potential difference** across it at constant temperature.

$$V = R \times I$$

B- Write the chemical equation:

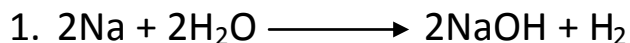

We must use very small piece of sodium.

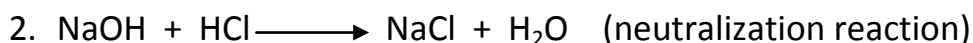

C- Nature of the reactant, concentration of the reactants, temperature and catalyst.

Q4: A- Mendel's hypotheses:

- The hereditary traits are transmitted from the parent to the offspring by Genes.
- Every hereditary trait is controlled by 2 hereditary factors (one from the father and one from the mother).
- These factors **are similar** in case of **pure traits** and **different** in case of **impure traits**.
- The living organism that carries **impure traits** is called **Hybrid**.
- The 2 hereditary **factors separate during the formation of Gametes**. So the gamete carries one hereditary factor of the trait.

B- Scientific idea:

1. The gene of the curly hair dominates over the gene of the smooth hair, if they are both present in an individual.
1. By making induced mutation (change in the hereditary factors of the plant to obtain desirable traits in specific living organisms (plants)
Ex: inducing fruits larger in size, larger fruits, better in taste, and free of seeds.

C- DNA

Watson and Crick they explained the structure of DNA as double helix like spiral ladder

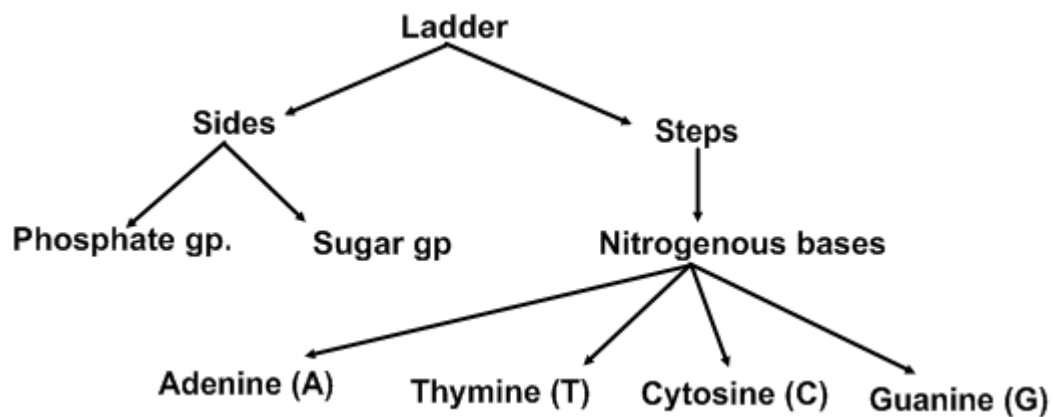

Adenine binds to Thymine by 2 hydrogen bonds A=T

Cytosine binds to Guanine by 3 hydrogen bonds C≡G

Examination 5

Q1: Complete:

1. Mercury, oxygen.
2. 2NaNO_2 , O_2
3. ZnCl_2 , H_2
4. Nature of the reactants, concentration of reaction, temperature of the reaction, catalyst.

Q2:A- Compare:

1- Oxidizing agent	Reducing agent
It is the substance which <i>gives oxygen</i> or <i>takes hydrogen</i> away during chemical reaction.	It is the substance which <i>takes oxygen</i> or <i>gives hydrogen</i> away during chemical reaction.
Or	Or
It is the substance which <i>gains an electron or more</i> during chemical reaction.	It is the substance which <i>gains an electron or more</i> during chemical reaction.

2-Points of comparison	Direct electric current	Alternating electric current
1- Intensity	With constant intensity	With variable intensity
2- Direction of flow	Flows in one direction only (the electrons flow from one pole of the cell passing through the circuit then returns to the other pole)	Flows in two opposite directions (the electrons flow in one direction in the beginning, then start to flow in the opposite direction)
3- Sources	Electrochemical cells (Batteries)	Electric generators (Dynamamos)
4- Distance they can transfer	Short distance.	Can be transferred to short and long distances.
5- Change to another type	Can't be converted into alternating current.	Can be converted into direct current.
6- Uses	<u>Used in:</u> 1. Electroplating. 2. Electrolysis process. 3. Operating of some electric machines.	<u>Used in:</u> 1. Lighting houses. 2. Operating electric applications

7- Graph

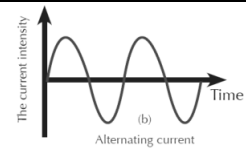
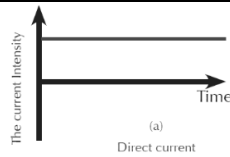

B- Put \checkmark or X

1. X (gains electron)
2. X (gigantism)
3. \checkmark

Q3:A- Explain:

1-



Effervescent tablet in
Hot water



Effervescent tablet in
Cold water

Obs.: more and faster effervescence in the first glass with hot water.

Conclusion: *the speed of chemical reactions increases by increasing the temperature.*

2- Set a circuit as shown in the figure

Take the reading of ammeter to get the current intensity (I)

Take the reading of voltmeter to get the potential difference (V)

Then use Ohm's law to get the resistance (R)

$$R = V/I$$

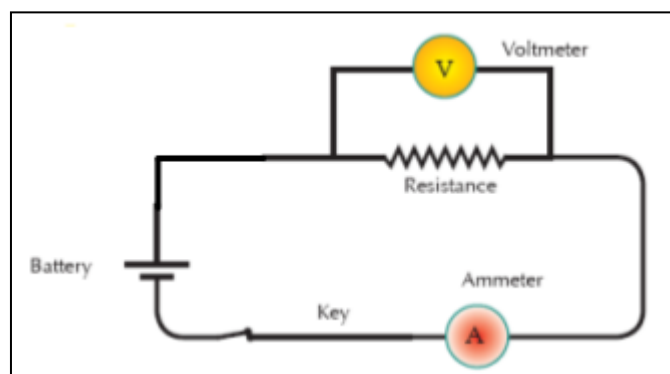

B- What is meant by?

1. The radioactivity phenomenon is known as the spontaneous conversion of the atom's nuclei of some elements that are present in nature in an attempt to achieve a more stable composition.

2. It is the mixture in which the solute molecules are distributed in the solvent in an **irregular** way in all its parts.
3. It is a substance whose aqueous solutions contains negative hydroxide ion OH^-
4. It is the mutation occurs on genes by man.

Q4:A-

1-Connection in parallel

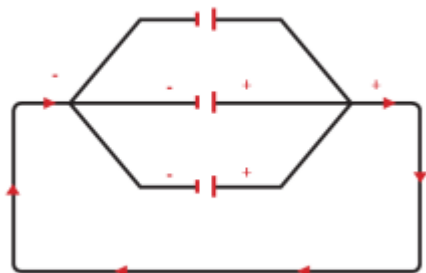

Connection in series

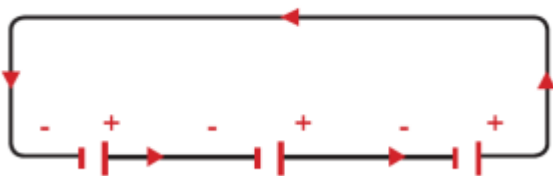

2-

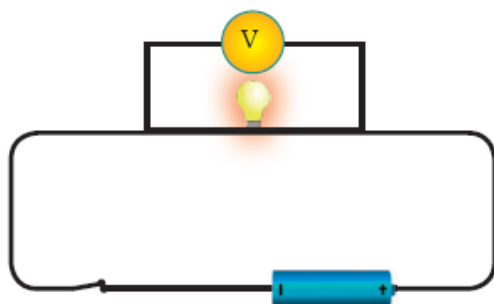

B- Give reason for:

1. Because it is acquired trait that can't be inherited from a generation to another.
2. Because magnesium replaces the copper as it comes before copper in the chemical activity series and copper precipitate as reddish brown ppt.



Examination 6

Q1: Complete:

1. Breaking of bonds, formation of new bonds.
2. CuO, SO₃
3. Wrong question $\text{CuO} + \text{H}_2 \rightarrow \text{Cu} + \text{H}_2\text{O}$
4. Lactic acid.
5. Treatment and diagnosis of cancer.

Q2: Compare

1- Oxidation	Reduction
It is a chemical process which causes the increase of the oxygen percentage or the decrease of hydrogen percentage. Or It is a chemical process where the atom loses an electron or more.	It is a chemical process which causes the decrease of the oxygen percentage or the increase of hydrogen percentage. Or It is a chemical process where the atom gains an electron or more.

2- Ammeter	Voltmeter
Used to measure the current intensity. 	Used to measure the potential difference and emf. 

Q3: A- Put \checkmark or X

1. X (lose electron)
2. \checkmark
3. X (ductless glands)

B- $I = ?$ $q = 6000 \text{ col.}$ $t = 10 \text{ min} = 600 \text{ sec.}$

$$I = q/t = 6000/600 = 10 \text{ ampere.}$$

Q4: A- Explain an activity:

Activity:-

- Put **iron filings** in test **tube 1** and an **iron piece** in test **tube 2**.
- Put equal amount of dil HCl in both tubes.

Obs.:

Fast reaction occurs in tube 1, while slow reaction in tube 2



- The speed of the reaction in case of iron filings is faster because the surface area of iron filings is larger.
- The speed of the reaction in case of iron piece is slower because the surface area is smaller than that of iron filings.

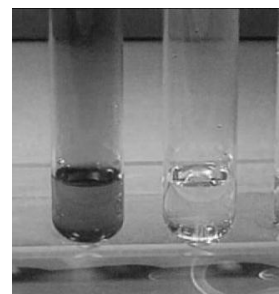

So

The reaction ends in case of iron filings in **shorter time** than that in case of iron piece.

So

The bigger the surface area exposed to the reaction the faster the reaction

2- Activity: to discover the relation between current intensity and potential difference:

- Set an electric circuit as shown in the opposite figure.
- Adjust the variable resistance till you get suitable reading of voltmeter and ammeter.
- Repeat the previous step several times by changing the length of the variable resistance and record the reading of voltmeter and ammeter each time.

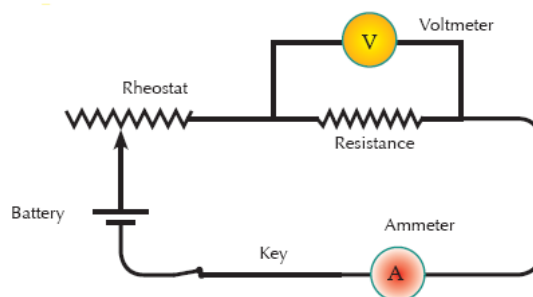

- Then calculate the resistance (R) by the following rule : **$R = V/I$**

Obs. : ratio between potential difference and current intensity is always **constant**.

$$V = R \times I$$

Conclusion: (Ohm's law) $R = V/I$

The **current** flowing through a metal conductor is **directly proportional** to the **potential difference** across it at constant temperature.

B- Define:

1. It is the mixture in which the solute molecules are distributed in the solvent in a ***regular*** way in all its parts.
2. It is the solution which **accepts the dissolution of an additional amount of the solute with the increase in temperature** (the amount of the solute is greater than in the case of the saturated solution).
3. It is a substance whose aqueous solutions contains a positive hydrogen ion H^+
4. It is the value of the work done to transfer a quantity of charge (1 coulomb) between the two ends of this conductor.

Good luck